

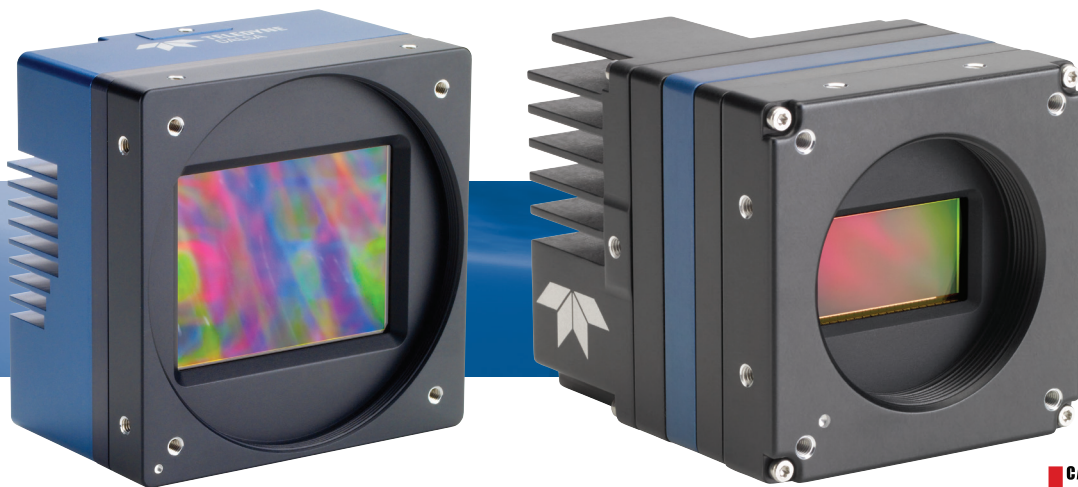

# Falcon™ 4 CLHS Cameras

## True High-Performance: High-Speed Global Shutter CMOS Cameras

When you need true high-performance imaging, turn to the Falcon™4-CLHS camera series. Using Teledyne Imaging's **advanced CMOS architectures**, the Falcon4-CLHS cameras offer **unique, unprecedented capabilities** for large area, high resolution, high speed imaging. Models include the high-speed 11.2 MP camera with a frame rate up to 609 fps and the high-resolution 86 MP camera with a frame rate up to 16 fps.



### Key Features

- Reduced dark noise levels and improved dark offset
- Improved sensitivity, including NIR response
- In-camera image pre-processing (flat field, pixel correction)
- Large full well when using in-sensor binning >160Ke
- Global shutter and exposure control
- Thousands of frames per second in Partial Scan Mode (ROI)

### Programmability

- Customizable user settings
- Programmable exposure time
- Adjustable analog / digital gain and offset
- Adjustable integration time and frame rate
- Test patterns and camera diagnostics

### Reliability

- Robust all-metal body
- 3-year warranty

### Typical Applications

- Electronic Inspection
- Aerial Imaging
- Flat Panel Inspection
- Semiconductor
- High Speed 3D imaging
- Surveillance
- Motion Tracking and Analysis

### Regulatory Compliance

- CE and RoHS compliant

## FALCON4-CLHS INDIVIDUAL MODEL SPECIFICATIONS

	Active Resolution	Sensor Model	Frame Rate (Burst Mode)	Pixel Size	Dynamic Range	Max. Image Circle	Data Format	Part Number
● Falcon4-CLHS M4480	4480 x 2496	Teledyne e2v Lince 11 MP	609 fps	6.0 µm	61.3 dB	APS-C	8 or 10-bit Mono	FA-HM00-M4485
● Falcon4-CLHS M4400	4480 x 2496	Teledyne e2v Lince 11 MP	330 fps	6.0 µm	61.3 dB	APS-C	8 or 10-bit Mono	FA-HM01-M4405
● Falcon4-CLHS 86M	10720 x 8064	Teledyne DALSA IA-M1-0086M 86 MP	16 fps	6.0 µm	56 dB	Medium Format	8, 12 or 16-bit Mono	FA-S0-86Mxx

## FALCON4-CLHS FAMILY SPECIFICATIONS (Common to all models)

	FALCON4 (Medium Case) p / n: FA-Hxxx-xxxx5	FALCON4 (Large Case) p / n: FA-S0-86Mxx
Data Output Transfer	CLHS 4 or 7-Lanes - 10.3 Gb / sec. per Lane	CLHS 7-Lanes - 3.125 Gb / sec. per Lane
Exposure Control	INTERNAL: Programmable via the camera API, EXTERNAL: Based on Trigger Width	
I/O Ports	2 input / 3 Output, Opto-coupled	2 input / 2 Output, Differential
Lens Mount	M42 x 1 mm	M95 x 1 mm
Size (L x H x W)	59 mm x 59 mm x 70 mm	100 mm x 100 mm x 70.5 mm
Mass	317 g	< 1 Kg
Operating Temp	-20 to +65°C (Housing Temperature)	0 °C to +50 °C (Housing Temperature)
Power Supply	10 V to 30 V DC	12 V to 24 V DC
Power Dissipation (model dependent)	< 13 W	< 35 W
Data Connector	CLHS CX4	
Power and I/O Connector	SAMTEC TFM-105 type	Hirose 12-pin circular
Camera Specification	Camera Link HS X-protocol	Camera Link HS M-protocol
Software Platform	Teledyne Sapera LT 8.50 (Windows or Linux)	



**RESPONSIVITY GRAPHS**

**Spectral Sensitivity Characteristics**

Excludes lens characteristics and light source characteristics

**Falcon4-CLHS M4480 / M4400**

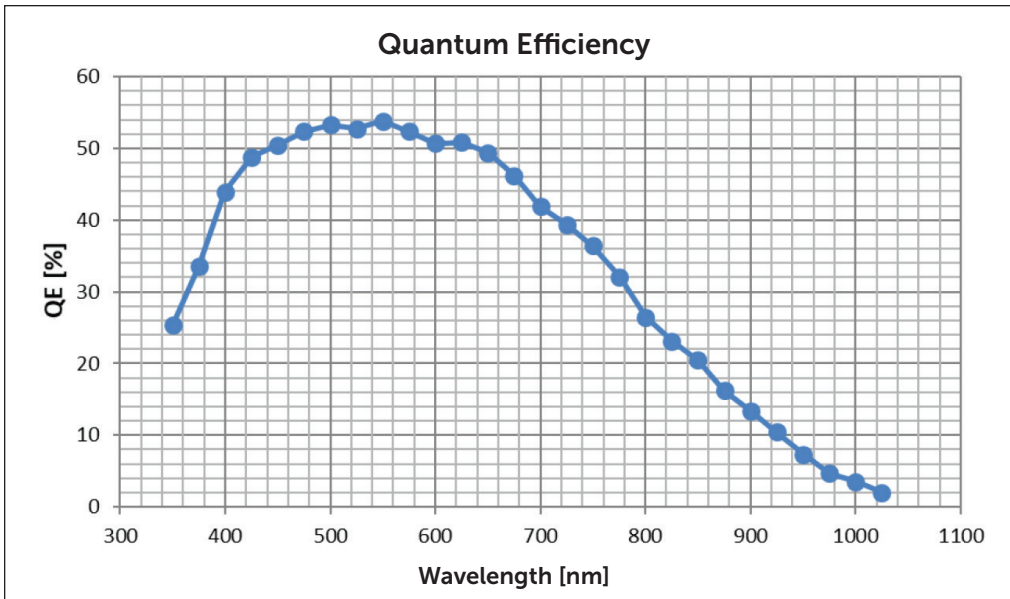

**Falcon4-CLHS 86M**

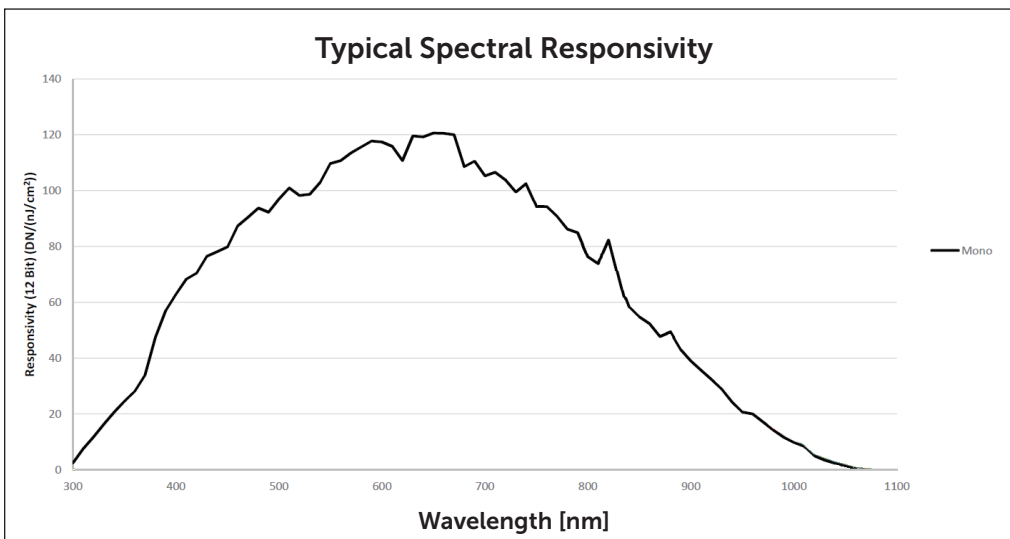

**SPECIFICATIONS: Falcon4-CLHS FA-Hxxx-xxxx5 Medium Case**

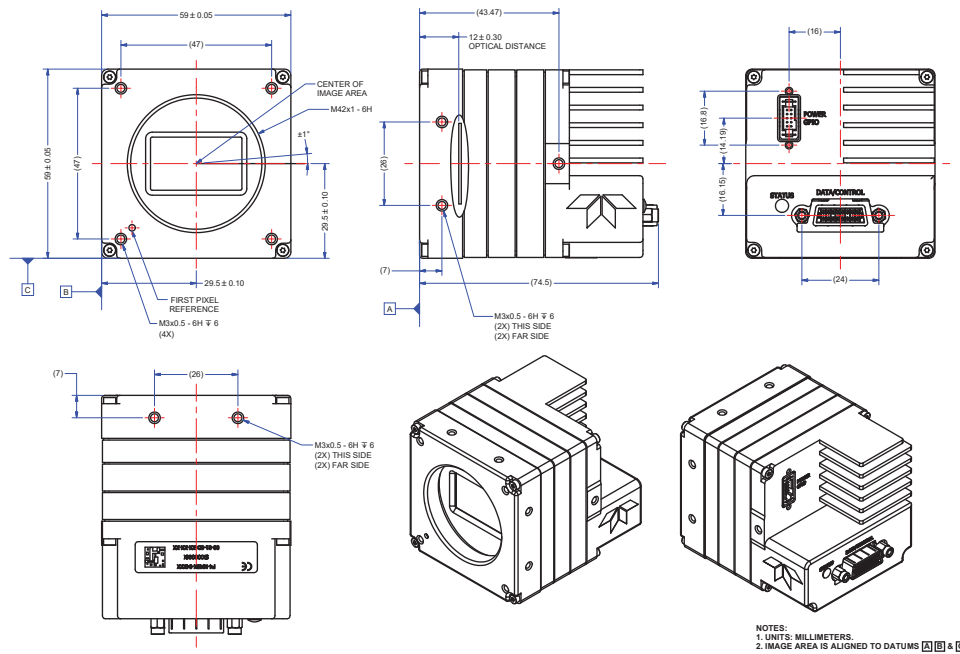

**SPECIFICATIONS: Falcon4-CLHS FA-S0-86Mxx Large Case**

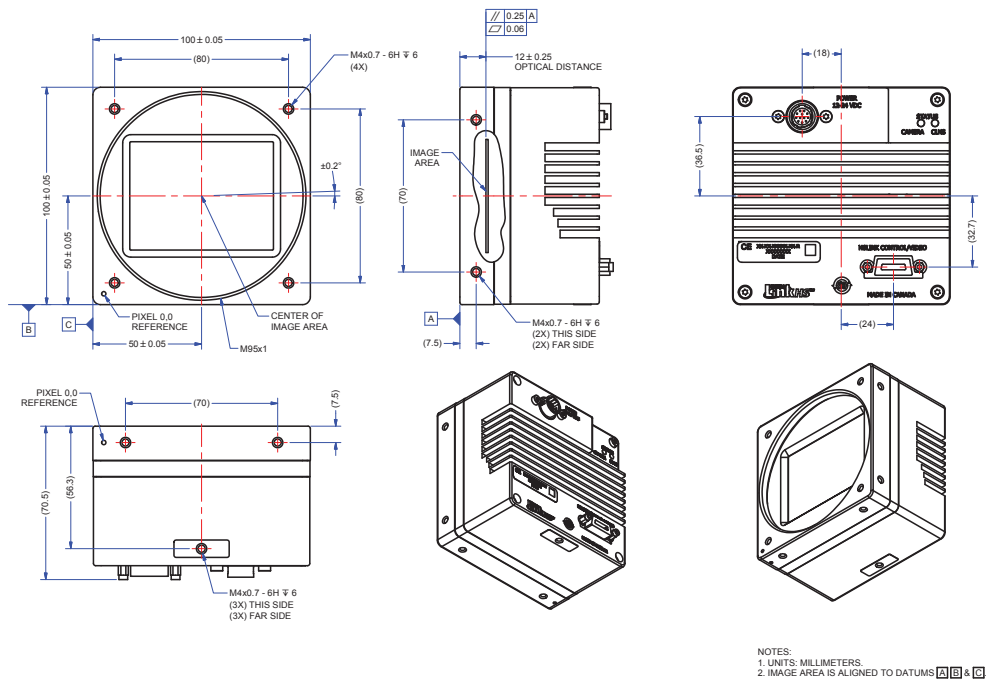

**Americas**  
Boston, USA  
+1 978-670-2000  
sales.americas@teledynedalsa.com

**Europe**  
Krailing, Germany  
+49 89-89-54-57-3-80  
sales.europe@teledynedalsa.com

**Asia Pacific**  
Tokyo, Japan  
+81 3-5960-6353  
sales.asia@teledynedalsa.com

Shanghai, China  
+86 21-3368-0027  
sales.asia@teledynedalsa.com